



33 Ochterloney Street, Dartmouth, NS

# Downtown Dartmouth Office Space for Lease

**Linda Harrie**

Senior Vice President Sales and Leasing  
+1 902 425 4396 (Direct) | +1 902 830 3360 (Mobile)  
Linda.Harrie@colliers.com



# Property Overview



**Walkable from Alderney Ferry Terminal**



**Office leaseholds in place**



**Excellent Downtown Dartmouth location**



**Complimentary surrounding uses**



**Underground parking included (at market rates)**

Prime office spaces available on the 1st and 2nd floors of a well-positioned, three-story office building - minutes away from the Dartmouth waterfront.

Downtown Dartmouth offers convenient ferry and bridge connections to Halifax and a walkable, community-focused vibe. The area is rejuvenated with trendy cafés, local businesses, and waterfront views.

|                        | Suite   | Size     | Availability |
|------------------------|---|----------|--------------|
| <b>Available Space</b> | 140   | 1,571 SF | Immediately  |
|                        | 142   | 600 SF   | Immediately  |
|                        | 200   | 974 SF   | Immediately  |
|                        | 210   | 1,115 SF | Immediately  |
|                        | *Suites 200 & 210 can be combined for 2,089 SF                  |          |              |
| <b>Location</b>        | Downtown Dartmouth  |          |              |
| <b>Parking</b>         | Underground parking (market rates)<br>Ample paid street parking |          |              |
| <b>Net Rent</b>        | Contact listing agent for rates                                 |          |              |
| <b>Additional Rent</b> | \$10.22 (est 2026)  |          |              |



**Bike Score**

71



**Walk Score**

95



**Transit Score**

67

\* Rated out of 100

# Floor Plans

Suite 140 | 1,571 SF

Available immediately

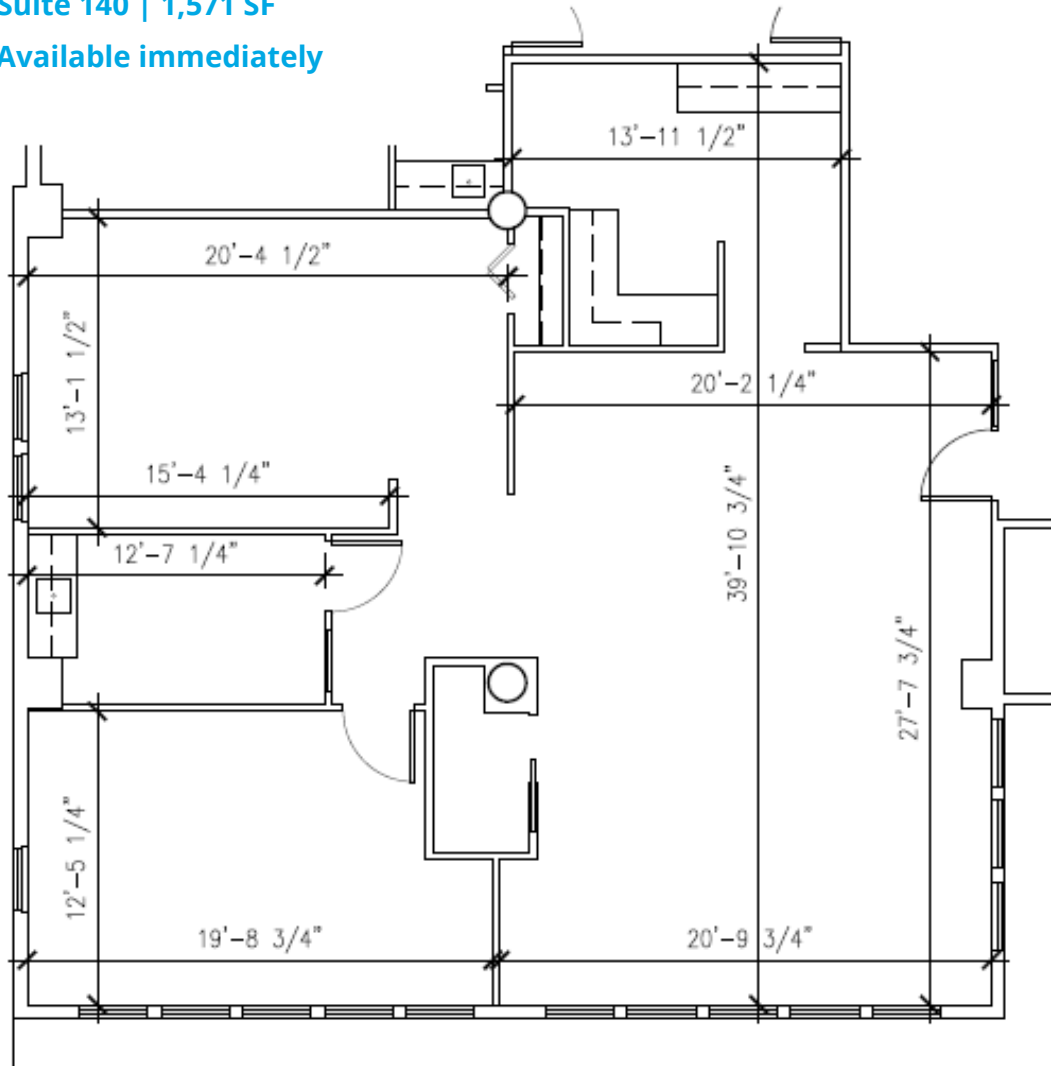

# Floor Plans

Suite 142 | 600 SF

Available immediately

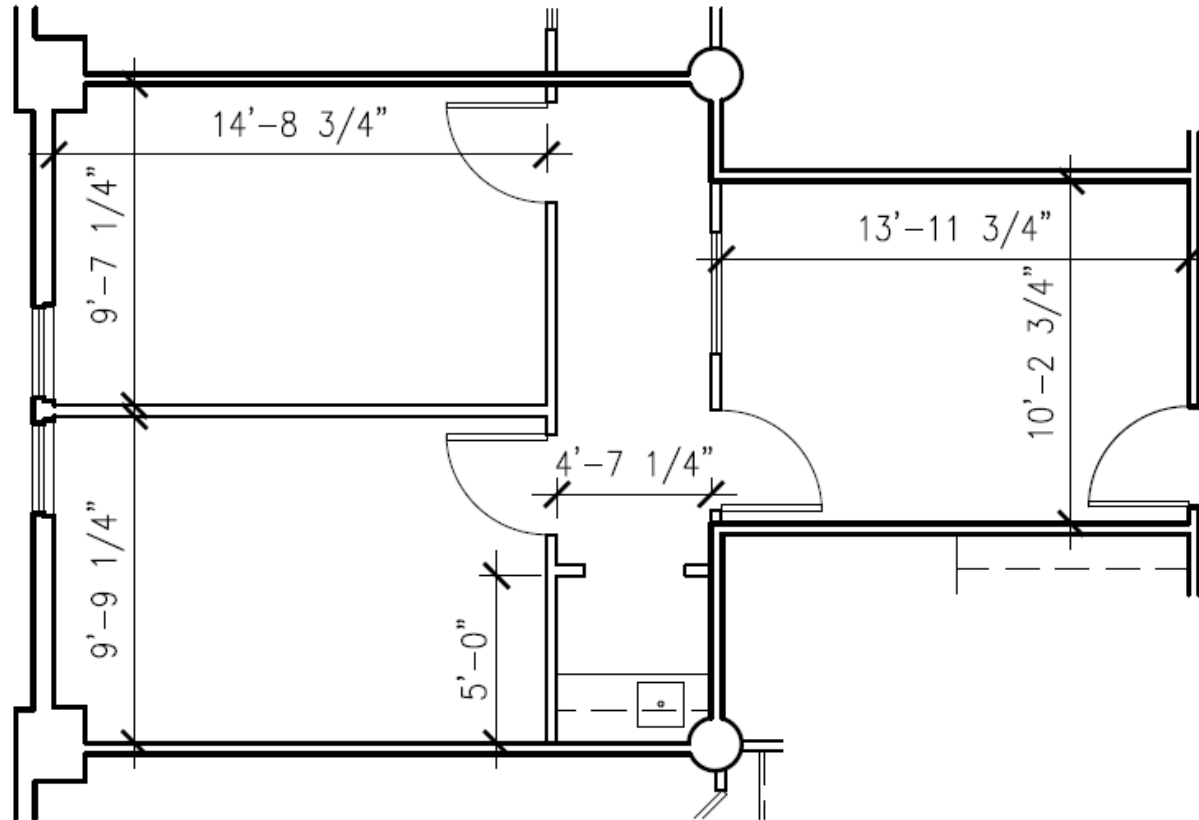

# Floor Plans

Suites 200 & 210 can be combined for 2,089 SF

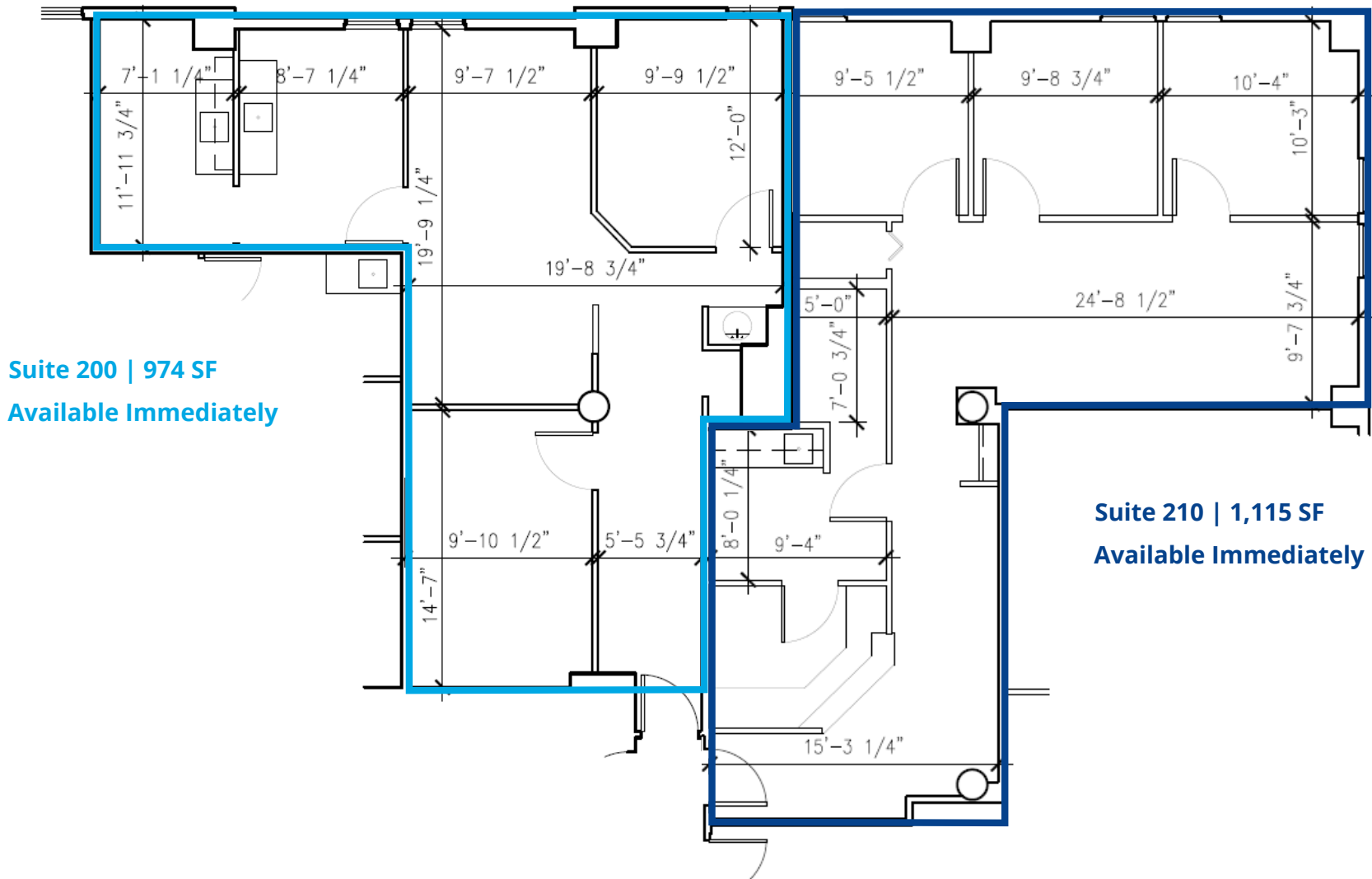

# Location Overview

The property is located in Downtown Dartmouth, a flourishing and spirited community with more than 200 businesses serving a growing population. The neighbourhood has undergone a metamorphosis in recent years into a hip and vibrant space with further growth on the horizon.

Within walking distance of the property are restaurants & bars, multiple parks, the public library, Dartmouth Commons walking trails, Sullivan's Pond, Lake Banook, and the Alderney Ferry Terminal. A short commute away is the Zatzman Sportsplex, Mic Mac Mall, Burnside Business Park, and Dartmouth Crossing.

## Demographics: 10 km Radius



**Current Population 2025** 324,004



**Projected Population 2035** 376,928



**Average Household Income 2025** \$106,469





33 Ochterloney Street | Dartmouth, NS

**Linda Harrie**

Senior Vice President Sales and Leasing  
+1 902 425 4396 (Direct) | +1 902 830 3360 (Mobile)  
Linda.Harrie@colliers.com

**Colliers Nova Scotia**

220 - 238 Brownlow Avenue  
Dartmouth, NS B3B 1Y2  
+1 902 422 1422

This document has been prepared by Colliers for advertising and general information only. Colliers makes no guarantees, representations, or warranties of any kind, expressed or implied regarding the information including, but not limited to, warranties of content, accuracy and reliability. Any interested party should undertake their own inquiries as to the accuracy of the information. Colliers excludes unequivocally all inferred or implied terms, conditions and warranties arising out of this document and excludes all liability for loss and damages arising there from. This publication is the copyrighted property of Colliers and / or its licensor(s). Copyright © 2026. All rights reserved. This communication is not intended to cause or induce breach of an existing listing agreement. Colliers International (Nova Scotia) Inc., Brokerage.



[collierscanada.com](https://www.collierscanada.com)