

KEY PLAN

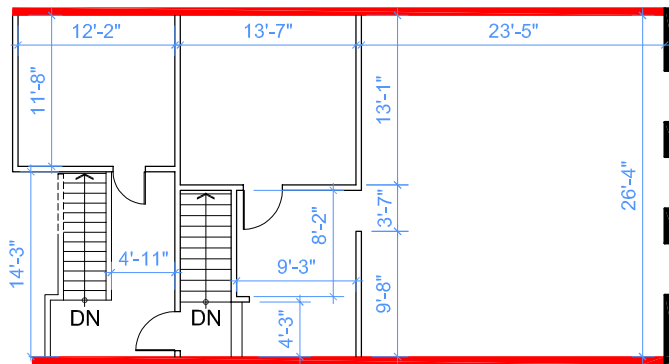

MEZZANINE

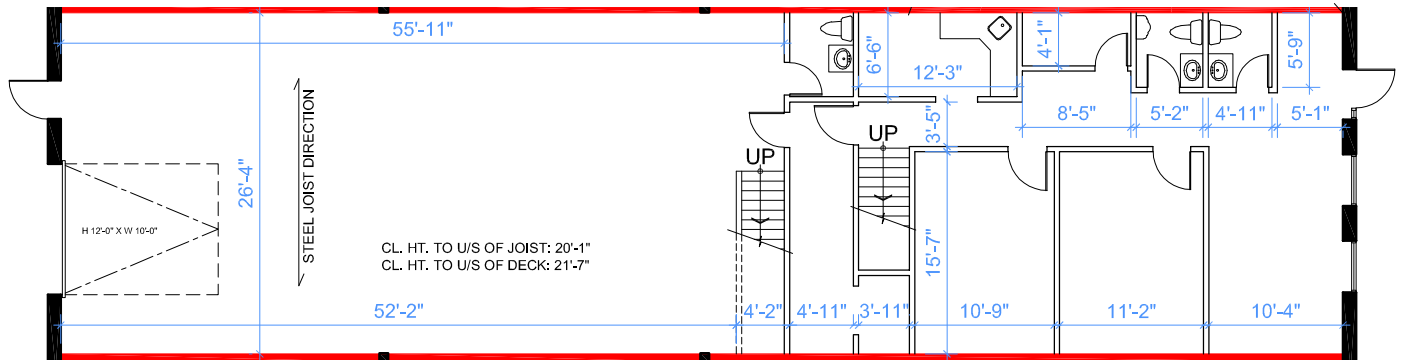

GROUND FLOOR

AREA SUMMARY

	RENTABLE AREA
OFFICE	1,192 S.F.
WAREHOUSE	1,548 S.F.
MEZZANINE	1,280 S.F.
TOTAL	4,020 S.F.

ABOVE INFORMATION ESTABLISHED ACCORDING TO THE BOMA/SIOR INDUSTRIAL STANDARD ANSI / BOMA Z65.2 2012 - METHOD A

— DEMISING WALL

