

VACANCY PLAN - UNIT 16

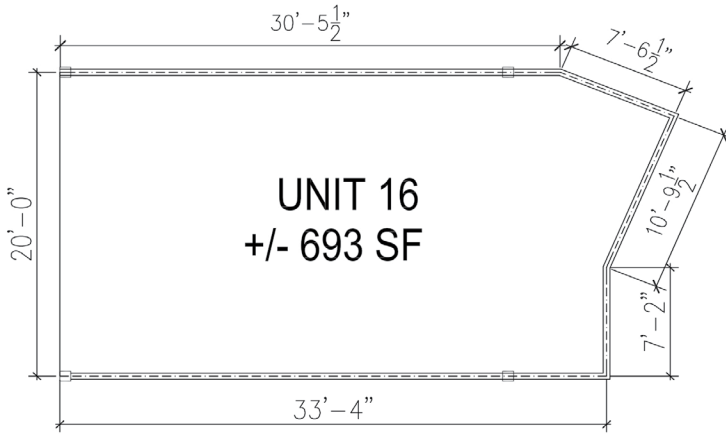

SITE PLAN



UNIT DETAILS

Date Available	Immediately
Description	Smaller size unit ideal for small retail business or service, located near Centre Court and Atmosphere's entrance to the mall.

CONTACT

Dave Mills
Property Manager, Vancouver Island
T 778 382 7767
C 250 713 6451
dave@nwproperties.ca

Christoph Richter
VP, Portfolio Management
T 604 629 8132
C 604 220 3286
christoph@nwproperties.ca

Kyle Silgailis
Property Manager
T 604 629 8121
C 604 329 7337
kyle@nwproperties.ca

nwproperties.ca