

SECOND FLOOR
 2493-99 BEACON AVE-
 9780-90 2ND STREET
 SIDNEY BC

2ND FLOOR

BEACON AVENUE

2ND
 24
 97
 SI
 2ND STREET

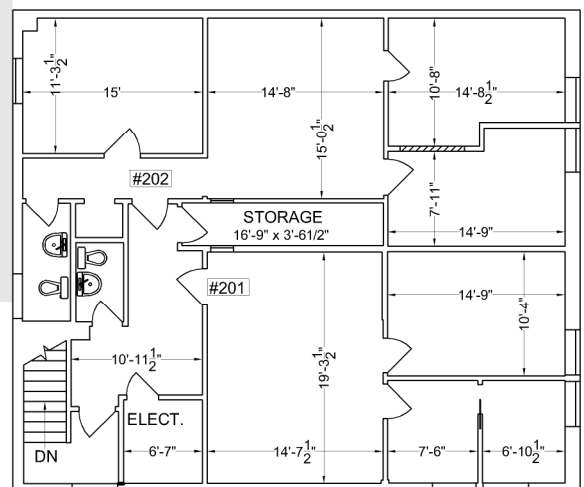
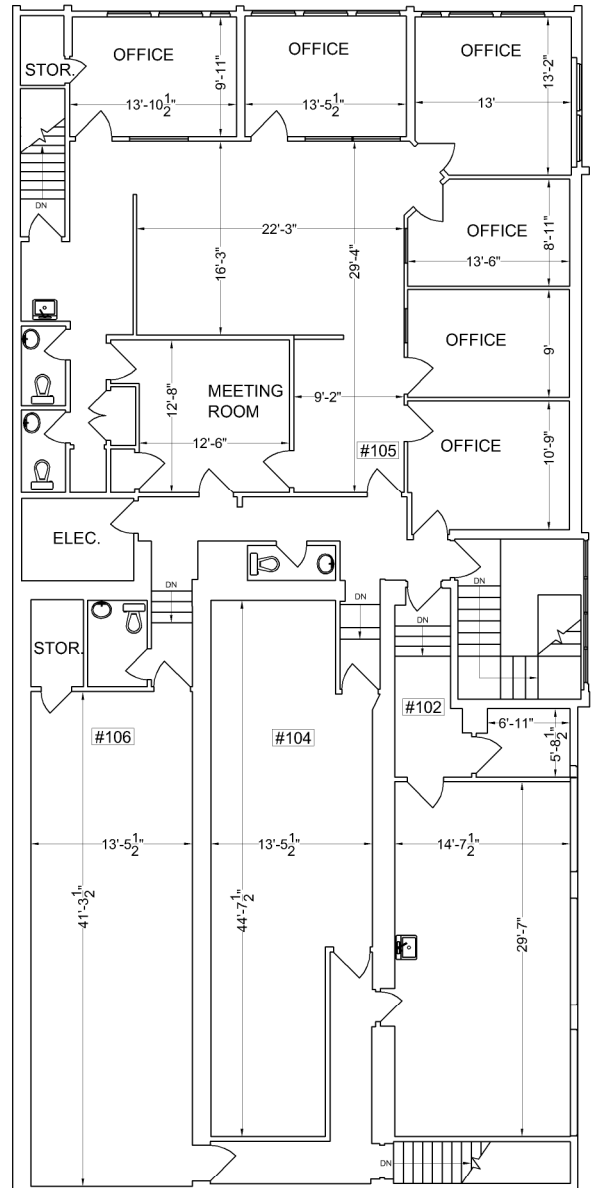

0 5' 10' 20'

MEASURED DEC 2009, Jul-2012

CORNERSTONE PROPERTIES LTD.
 #301-1001 CLOVERDALE AVE.
 VICTORIA BC V8X-4C9
 TEL 250 475 2005
 FAX 250 475 2008

SECOND FLOOR
 2493-99 BEACON AVE-
 9780-90 2ND STREET
 SIDNEY BC

FLOOR PLAN

27 July 2012

12-1773

1/16" = 1'-0"



MEASURE MASTERS
 VANCOUVER ISLAND - COMMERCIAL
 3034 WESTDOWNE ROAD
 VICTORIA BC V8R 5G2
 TEL 250 472 2653 FAX 250 472 2683